

Code No: 132AE

R16

JAWAHARLAL NEHRU TECHNOLOGICAL UNIVERSITY HYDERABAD

B. Tech I Year II Semester Examinations, September - 2023

ENGINEERING GRAPHICS

(Common to EEE, ECE, CSE, EIE, IT)

Time: 3 hours

Max Marks: 75

**Answer any five questions
All questions carry equal marks**

1. Construct an epi-cycloid when the generating or rolling circle diameter is 45 mm. and diameter of directing circle is 135 mm. Draw normal and tangent to the curve from a point 10 mm above the centre of rolling circle. [15]

OR

2. Draw a hyperbola when the eccentricity is $\frac{4}{3}$ and the distance of focus is 75 mm from the directrix. Draw the tangent and normal to the curve from a point 35 mm from focus. [15]

3. A line AB of 65 mm has its end A 20 mm above HP and 25 mm in front of VP. It is inclined at 30° to HP and 45° to VP. Draw the projections. [15]

OR

4. A circular lamina of 5 cm diameter is resting on a point on its circumference and its surface makes an angle of 30° to H.P. and perpendicular to V.P. draw the projections. [15]

5. A square prism of side 35 mm axis 70 mm resting on one of its base edges on H.P. and makes an angle of 45° to V.P. Its axis makes an angle of 30° to H.P. Draw the projections. [15]

OR

6. A square pyramid of side 4 cm and height 7 cm is resting on one of its triangular faces on H.P. such that the base edge on which it is resting makes an angle of 45° with V.P. Draw the projections. [15]

7. A cylinder of 4 cm diameter 7 cm height is resting on its base on H.P. It is cut by a section plane perpendicular to V.P. and inclined at 30° to H.P. and passing through a point 10 mm below the top centre. Draw the front view, sectional top view and true shape of section. [15]

OR

8. Draw the development of a hexagonal pyramid of side 3 cm and height 7 cm is resting on its base on H.P. It is cut by a section plane perpendicular to V.P. and inclined at 40° to H.P. and passing through a point 20 mm below the apex. [15]

QA QA QA QA QA QA QA Q

9. A cone of 3 cm diameter height 5 cm is placed centrally on the top face of a frustum of a square pyramid of top face side 4.5 cm and bottom face side 7 cm with a height of 6 cm. Draw the isometric view of the combination. [15]

QA QA QA QA QA QA QA Q

10. Draw the front view, top view and side view for the component shown in figure below. (All dimensions are in mm) [15]

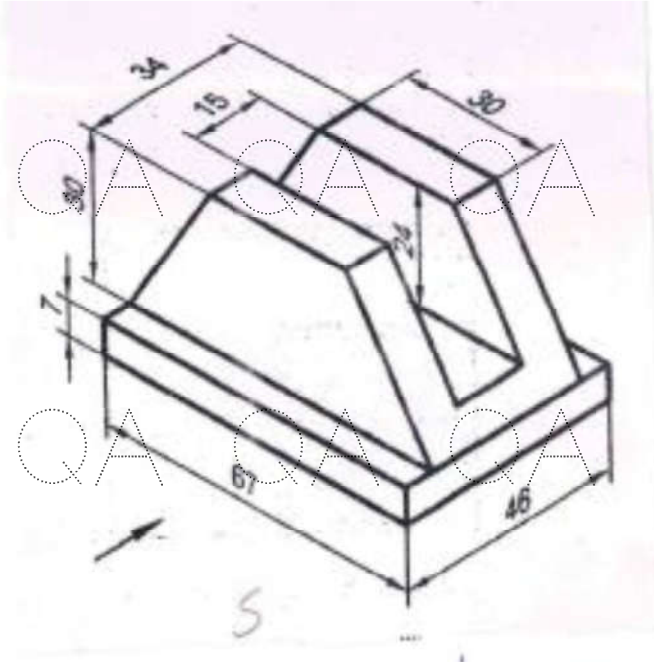

QA QA QA QA QA QA QA Q

QA QA QA QA QA QA QA Q

QA QA QA QA QA QA QA Q

---ooOoo---

QA QA QA QA QA QA QA Q

QA QA QA QA QA QA QA Q

QA QA QA QA QA QA QA Q